

DETAY - A DETAY - B DETAY - C
DETAIL - A DETAIL - B DETAIL - C

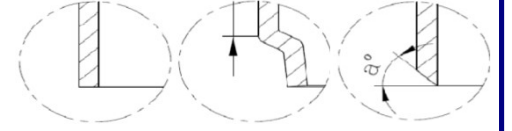

| Ürün Kodu Product Code | øD mm | h3 mm | t mm | Detay Detail |
|---------------------------|----------|----------|---------|-----------------|
| TB600-02-00001 | 48 | 21 | 2 | A |
| TB600-02-00002 | 48 | 23 | 3 | A |
| TB600-02-00003 | 48 | 26 | 4 | A |
| TB600-02-00004 | 60 | 24 | 2 | A |
| TB600-02-00005 | 60 | 26 | 3 | A |
| TB600-02-00006 | 60 | 29 | 4 | A |
| TB600-02-00007 | 76 | 28 | 2 | A |
| TB600-02-00008 | 76 | 30 | 3 | A |
| TB600-02-00009 | 76 | 33 | 4 | A |
| TB600-02-00261 | 89 | 31 | 2 | A |
| TB600-02-00010 | 89 | 34 | 3 | A |
| TB600-02-00011 | 89 | 36 | 4 | A |
| TB600-02-00268 | 89 | 39 | 5 | A |
| TB600-02-00012 | 114 | 38 | 2 | A |
| TB600-02-00013 | 114 | 40 | 3 | A |
| TB600-02-00014 | 114 | 43 | 4 | A |
| TB600-02-00015 | 114 | 45 | 5 | A |
| TB600-02-00145 | 114 | 47 | 6 | A |
| TB600-02-00147 | 114 | 52 | 8 | A |
| TB600-02-00264 | 114 | 57 | 10 | A |
| TB600-02-00016 | 140 | 44 | 2 | A |
| TB600-02-00017 | 140 | 47 | 3 | A |
| TB600-02-00018 | 140 | 49 | 4 | A |
| TB600-02-00019 | 140 | 52 | 5 | A |
| TB600-02-00188 | 140 | 54 | 6 | A |
| TB600-02-00189 | 140 | 56 | 7 | A |
| TB600-02-00182 | 140 | 59 | 8 | A |
| TB600-02-00183 | 140 | 63 | 10 | A |
| TB600-02-00020 | 168 | 52 | 2 | A |
| TB600-02-00021 | 168 | 54 | 3 | A |
| TB600-02-00022 | 168 | 56 | 4 | A / B |
| TB600-02-00023 | 168 | 59 | 5 | A / B |
| TB600-02-00190 | 168 | 61 | 6 | A / B |
| TB600-02-00191 | 168 | 63 | 7 | A |
| TB600-02-00146 | 168 | 66 | 8 | A |
| TB600-02-00148 | 168 | 70 | 10 | A |
| TB600-02-00024 | 205 | 61 | 2 | A / B |
| TB600-02-00025 | 205 | 63 | 3 | A / B |
| TB600-02-00026 | 205 | 66 | 4 | A / B |
| TB600-02-00027 | 205 | 68 | 5 | A / B |

Notlar:

•h3 ölçüsü müşteri talebine göre değiştirilebilmektedir.

/ h3 dimension can be changed on customer request.

•t = ham malzeme kalınlığı

/ t = raw material thickness

•Ölçü toleransları için satış bölümümüze danışınız.

/ Please contact our sales team for dimension tolerances.

•Siparişte ürün kodu ve malzeme kalitesi ile birlikte bombe kenar detayını (A / B) mutlaka belirtiniz.

C detayı için satış bölümümüze danışınız.

/ In your inquires, please indicate product code, edge detail (A / B) and material grade. Please contact our sales team for C detail.

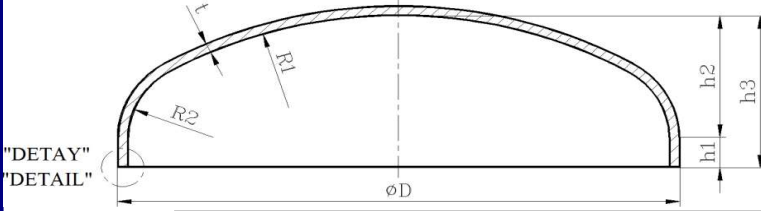

DETAY - A DETAY - B DETAY - C
DETAIL - A DETAIL - B DETAIL - C

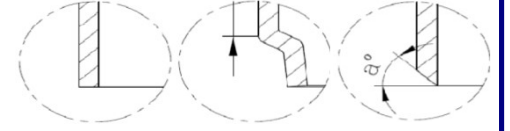

| Ürün Kodu Product Code | øD mm | h3 mm | t mm | Detay Detail |
|---------------------------|----------|----------|---------|-----------------|
| TB600-02-00028 | 219 | 65 | 2 | A / B |
| TB600-02-00029 | 219 | 67 | 3 | A / B |
| TB600-02-00030 | 219 | 67 | 3 | A / B |
| TB600-02-00031 | 219 | 69 | 4 | A / B |
| TB600-02-00032 | 219 | 72 | 5 | A / B |
| TB600-02-00033 | 219 | 74 | 6 | A |
| TB600-02-00192 | 219 | 76 | 7 | A |
| TB600-02-00156 | 219 | 79 | 8 | A |
| TB600-02-00156 | 219 | 83 | 10 | A |
| TB600-02-00034 | 250 | 72 | 2 | A / B |
| TB600-02-00035 | 250 | 75 | 3 | A / B |
| TB600-02-00036 | 250 | 77 | 4 | A / B |
| TB600-02-00037 | 250 | 80 | 5 | A / B |
| TB600-02-00038 | 273 | 78 | 2 | A / B |
| TB600-02-00039 | 273 | 81 | 3 | A / B |
| TB600-02-00040 | 273 | 83 | 4 | A / B |
| TB600-02-00041 | 273 | 85 | 5 | A / B |
| TB600-02-00185 | 273 | 88 | 6 | A / B |
| TB600-02-00185 | 273 | 93 | 8 | A |
| TB600-02-00042 | 300 | 85 | 2 | A / B |
| TB600-02-00043 | 300 | 88 | 3 | A / B |
| TB600-02-00044 | 300 | 90 | 4 | A / B |
| TB600-02-00045 | 300 | 92 | 5 | A / B |
| TB600-02-00046 | 323 | 91 | 2 | A / B |
| TB600-02-00047 | 323 | 93 | 3 | A / B |
| TB600-02-00048 | 323 | 96 | 4 | A / B |
| TB600-02-00049 | 323 | 98 | 5 | A / B |
| TB600-02-00186 | 323 | 101 | 6 | A / B |
| TB600-02-00149 | 323 | 103 | 7 | A |
| TB600-02-00239 | 323 | 105 | 8 | A |
| TB600-02-00240 | 323 | 110 | 10 | A |
| TB600-02-00230 | 323 | 115 | 12 | A |
| TB600-02-00050 | 350 | 98 | 2 | A / B |
| TB600-02-00051 | 350 | 100 | 3 | A / B |
| TB600-02-00052 | 350 | 103 | 4 | A / B |
| TB600-02-00053 | 350 | 105 | 5 | A / B |
| TB600-02-00054 | 350 | 107 | 6 | A / B |
| TB600-02-00193 | 350 | 110 | 7 | A |
| TB600-02-00154 | 350 | 112 | 8 | A |
| TB600-02-00150 | 350 | 117 | 10 | A |

Notlar:

•h3 ölçüsü müşteri talebine göre değiştirilebilmektedir.

/ h3 dimension can be changed on customer request.

•t = ham malzeme kalınlığı

/ t = raw material thickness

•Ölçü toleransları için satış bölümümüze danışınız.

/ Please contact our sales team for dimension tolerances.

•Siparişte ürün kodu ve malzeme kalitesi ile birlikte bombe kenar detayını (A / B) mutlaka belirtiniz.

C detayı için satış bölümümüze danışınız.

/ In your inquires, please indicate product code, edge detail (A / B) and material grade. Please contact our sales team for C detail.

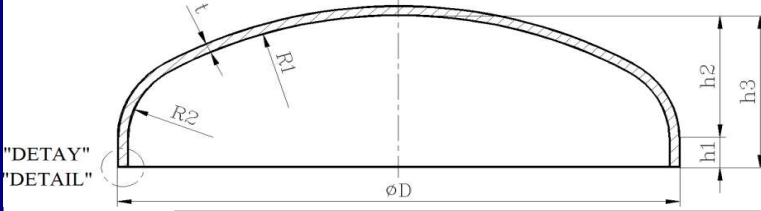

DETAİ - A DETAİ - B DETAİ - C
DETAİL - A DETAIL - B DETAIL - C

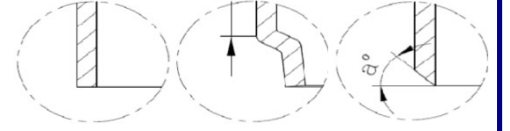

| Ürün Kodu Product Code | øD mm | h3 mm | t mm | DeTAİ Detail |
|---------------------------|----------|----------|---------|-----------------|
| TB600-02-00171 | 355 | 109 | 6 | A / B |
| TB600-02-00194 | 355 | 111 | 7 | A / B |
| TB600-02-00172 | 355 | 113 | 8 | A |
| TB600-02-00173 | 355 | 118 | 10 | A |
| TB600-02-00236 | 355 | 123 | 12 | A |
| TB600-02-00055 | 360 | 101 | 2 | A / B |
| TB600-02-00056 | 360 | 103 | 3 | A / B |
| TB600-02-00057 | 360 | 105 | 4 | A / B |
| TB600-02-00058 | 360 | 108 | 5 | A / B |
| TB600-02-00061 | 385 | 107 | 2 | A / B |
| TB600-02-00062 | 385 | 109 | 3 | A / B |
| TB600-02-00063 | 385 | 112 | 4 | A / B |
| TB600-02-00065 | 400 | 113 | 3 | A / B |
| TB600-02-00066 | 400 | 115 | 4 | A / B |
| TB600-02-00067 | 400 | 118 | 5 | A / B |
| TB600-02-00068 | 400 | 120 | 6 | A / B |
| TB600-02-00262 | 406 | 115 | 3 | A / B |
| TB600-02-00071 | 406 | 117 | 4 | A / B |
| TB600-02-00069 | 406 | 119 | 5 | A / B |
| TB600-02-00070 | 406 | 122 | 6 | A / B |
| TB600-02-00195 | 406 | 124 | 7 | A |
| TB600-02-00174 | 406 | 126 | 8 | A |
| TB600-02-00237 | 406 | 131 | 10 | A |
| TB600-02-00263 | 406 | 136 | 12 | A |
| TB600-02-00266 | 447 | 142 | 10 | A |
| TB600-02-00246 | 447 | 146 | 12 | A |
| TB600-02-00247 | 447 | 151 | 14 | A |
| TB600-02-00073 | 450 | 126 | 3 | A / B |
| TB600-02-00074 | 450 | 128 | 4 | A / B |
| TB600-02-00075 | 450 | 131 | 5 | A / B |
| TB600-02-00076 | 450 | 133 | 6 | A / B |
| TB600-02-00177 | 457 | 130 | 4 | A / B |
| TB600-02-00178 | 457 | 132 | 5 | A / B |
| TB600-02-00179 | 457 | 135 | 6 | A / B |
| TB600-02-00196 | 457 | 137 | 7 | A / B |
| TB600-02-00175 | 457 | 139 | 8 | A |
| TB600-02-00077 | 480 | 133 | 3 | A / B |
| TB600-02-00078 | 480 | 136 | 4 | A / B |
| TB600-02-00079 | 480 | 138 | 5 | A / B |
| TB600-02-00080 | 480 | 141 | 6 | A / B |
| TB600-02-00081 | 480 | 143 | 7 | A / B |
| TB600-02-00267 | 480 | 145 | 8 | A |

Notlar:

•h3 ölçüsü müşteri talebine göre değiştirilebilmektedir.

/ h3 dimension can be changed on customer request.

•t = ham malzeme kalınlığı

/ t = raw material thickness

•Ölçü toleransları için satış bölümümüze danışınız.

/ Please contact our sales team for dimension tolerances.

•Siparişte ürün kodu ve malzeme kalitesi ile birlikte bombe kenar detayını (A / B) mutlaka belirtiniz.

C detayı için satış bölümümüze danışınız.

/ In your inquires, please indicate product code, edge detail (A / B) and material grade. Please contact our sales team for C detail.

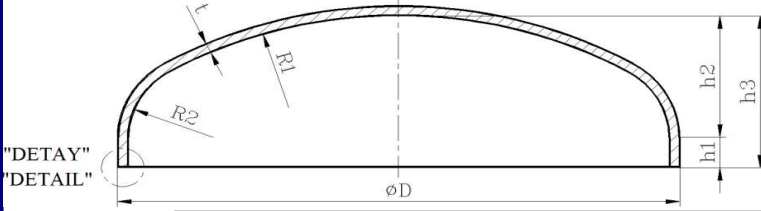

DETAY - A DETAY - B DETAY - C
DETAIL - A DETAIL - B DETAIL - C

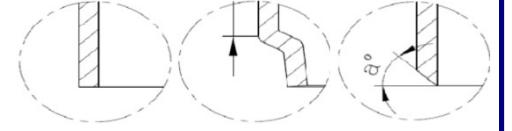

| Ürün Kodu Product Code | øD mm | h3 mm | t mm | Detay Detail |
|---------------------------|----------|----------|---------|-----------------|
| TB600-02-00082 | 500 | 136 | 2 | A / B |
| TB600-02-00083 | 500 | 139 | 3 | A / B |
| TB600-02-00084 | 500 | 141 | 4 | A / B |
| TB600-02-00085 | 500 | 143 | 5 | A / B |
| TB600-02-00086 | 500 | 146 | 6 | A / B |
| TB600-02-00180 | 508 | 145 | 5 | A / B |
| TB600-02-00181 | 508 | 148 | 6 | A / B |
| TB600-02-00197 | 508 | 150 | 7 | A |
| TB600-02-00182 | 508 | 152 | 8 | A |
| TB600-02-00176 | 508 | 157 | 10 | A |
| TB600-02-00088 | 545 | 150 | 3 | A / B |
| TB600-02-00089 | 545 | 152 | 4 | A / B |
| TB600-02-00090 | 545 | 155 | 5 | A / B |
| TB600-02-00091 | 545 | 157 | 6 | A / B |
| TB600-02-00271 | 550 | 163 | 8 | A |
| TB600-02-00093 | 600 | 164 | 3 | A / B |
| TB600-02-00094 | 600 | 166 | 4 | A / B |
| TB600-02-00095 | 600 | 169 | 5 | A / B |
| TB600-02-00096 | 600 | 171 | 6 | A / B |
| TB600-02-00249 | 608 | 173 | 6 | A / B |
| TB600-02-00238 | 608 | 176 | 7 | A |
| TB600-02-00209 | 608 | 178 | 8 | A |
| TB600-02-00210 | 608 | 183 | 10 | A |
| TB600-02-00211 | 608 | 187 | 12 | A |
| TB600-02-00098 | 640 | 174 | 3 | A / B |
| TB600-02-00099 | 640 | 177 | 4 | A / B |
| TB600-02-00100 | 640 | 179 | 5 | A / B |
| TB600-02-00101 | 640 | 181 | 6 | A / B |
| TB600-02-00198 | 640 | 184 | 7 | A |
| TB600-02-00102 | 640 | 186 | 8 | A |
| TB600-02-00208 | 640 | 191 | 10 | A |
| TB600-02-00269 | 650 | 203 | 14 | A |
| TB600-02-00104 | 700 | 190 | 3 | A / B |
| TB600-02-00105 | 700 | 192 | 4 | A / B |
| TB600-02-00106 | 700 | 194 | 5 | A / B |
| TB600-02-00107 | 700 | 197 | 6 | A / B |
| TB600-02-00109 | 750 | 202 | 3 | A / B |
| TB600-02-00110 | 750 | 205 | 4 | A / B |
| TB600-02-00111 | 750 | 207 | 5 | A / B |
| TB600-02-00215 | 750 | 209 | 6 | A / B |

Notlar:

•h3 ölçüsü müşteri talebine göre değiştirilebilmektedir.

/ h3 dimension can be changed on customer request.

•t = ham malzeme kalınlığı

/ t = raw material thickness

•Ölçü toleransları için satış bölümümüze danışınız.

/ Please contact our sales team for dimension tolerances.

•Siparişte ürün kodu ve malzeme kalitesi ile birlikte bombe kenar detayını (A / B) mutlaka belirtiniz.

C detayı için satış bölümümüze danışınız.

/ In your inquires, please indicate product code, edge detail (A / B) and material grade. Please contact our sales team for C detail.

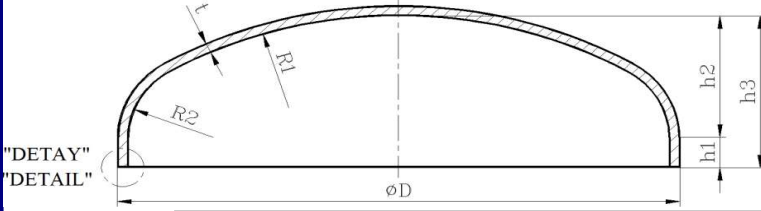

DETAİ - A DETAY - B DETAY - C
DETAIL - A DETAIL - B DETAIL - C

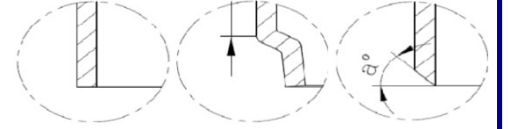

| Ürün Kodu Product Code | øD mm | h3 mm | t mm | Detay Detail |
|---------------------------|----------|----------|---------|-----------------|
| TB600-02-00266 | 770 | 229 | 12 | A |
| TB600-02-00270 | 770 | 233 | 14 | A |
| TB600-02-00251 | 800 | 232 | 10 | A |
| TB600-02-00252 | 800 | 236 | 12 | A |
| TB600-02-00253 | 800 | 239 | 13 | A |
| TB600-02-00113 | 804 | 216 | 3 | A / B |
| TB600-02-00114 | 804 | 218 | 4 | A / B |
| TB600-02-00115 | 804 | 221 | 5 | A / B |
| TB600-02-00116 | 804 | 223 | 6 | A / B |
| TB600-02-00151 | 804 | 226 | 7 | A |
| TB600-02-00117 | 804 | 228 | 8 | A |
| TB600-02-00118 | 850 | 225 | 2 | A / B |
| TB600-02-00119 | 850 | 228 | 3 | A / B |
| TB600-02-00120 | 850 | 230 | 4 | A / B |
| TB600-02-00121 | 850 | 233 | 5 | A / B |
| TB600-02-00122 | 850 | 235 | 6 | A / B |
| TB600-02-00199 | 850 | 237 | 7 | A / B |
| TB600-02-00123 | 850 | 240 | 8 | A / B |
| TB600-02-00216 | 850 | 244 | 10 | A |
| TB600-02-00256 | 900 | 241 | 3 | A / B |
| TB600-02-00257 | 900 | 243 | 4 | A / B |
| TB600-02-00258 | 900 | 245 | 5 | A / B |
| TB600-02-00259 | 900 | 248 | 6 | A / B |
| TB600-02-00229 | 905 | 273 | 16 | A |
| TB600-02-00166 | 958 | 258 | 4 | A / B |
| TB600-02-00167 | 958 | 260 | 5 | A / B |
| TB600-02-00168 | 958 | 262 | 6 | A / B |
| TB600-02-00200 | 958 | 265 | 7 | A / B |
| TB600-02-00169 | 958 | 267 | 8 | A / B |
| TB600-02-00130 | 1000 | 270 | 4 | A / B |
| TB600-02-00131 | 1000 | 273 | 5 | A / B |
| TB600-02-00132 | 1000 | 275 | 6 | A / B |
| TB600-02-00133 | 1000 | 278 | 7 | A / B |
| TB600-02-00134 | 1000 | 280 | 8 | A / B |
| TB600-02-00135 | 1100 | 296 | 4 | A / B |
| TB600-02-00136 | 1100 | 298 | 5 | A / B |
| TB600-02-00137 | 1100 | 301 | 6 | A / B |
| TB600-02-00138 | 1100 | 303 | 7 | A / B |
| TB600-02-00139 | 1100 | 305 | 8 | A / B |

Notlar:

•h3 ölçüsü müşteri talebine göre değiştirilebilmektedir.

/ h3 dimension can be changed on customer request.

•t = ham malzeme kalınlığı

/ t = raw material thickness

•Ölçü toleransları için satış bölümümüze danışınız.

/ Please contact our sales team for dimension tolerances.

•Siparişte ürün kodu ve malzeme kalitesi ile birlikte bombe kenar detayını (A / B) mutlaka belirtiniz.

C detayı için satış bölümümüze danışınız.

/ In your inquires, please indicate product code, edge detail (A / B) and material grade. Please contact our sales team for C detail.

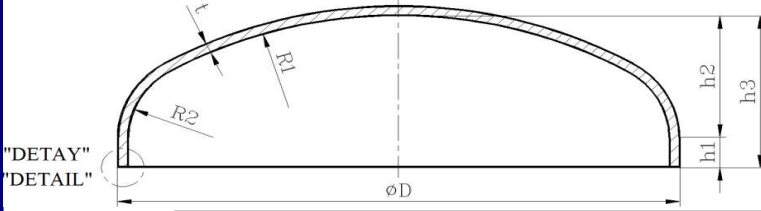

DETAY - A DETAY - B DETAY - C
DETAIL - A DETAIL - B DETAIL - C

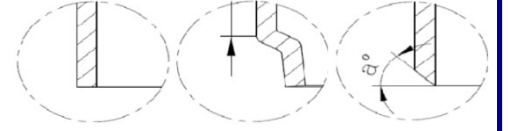

| Ürün Kodu Product Code | øD mm | h3 mm | t mm | Detay Detail |
|---------------------------|----------|----------|---------|-----------------|
| TB600-02-00158 | 1150 | 309 | 4 | A / B |
| TB600-02-00159 | 1150 | 311 | 5 | A / B |
| TB600-02-00160 | 1150 | 313 | 6 | A / B |
| TB600-02-00161 | 1150 | 316 | 7 | A / B |
| TB600-02-00162 | 1150 | 318,17 | 8 | A / B |
| TB600-02-00241 | 1150 | 322,9 | 10 | A |
| TB600-02-00248 | 1150 | 328 | 12 | A |
| TB600-02-00141 | 1200 | 321 | 4 | A / B |
| TB600-02-00142 | 1200 | 324 | 5 | A / B |
| TB600-02-00143 | 1200 | 326 | 6 | A / B |
| TB600-02-00201 | 1200 | 329 | 7 | A / B |
| TB600-02-00144 | 1200 | 331 | 8 | A / B |
| TB600-02-00204 | 1400 | 377 | 6 | A / B |
| TB600-02-00205 | 1400 | 380 | 7 | A / B |
| TB600-02-00206 | 1400 | 382 | 8 | A / B |
| TB600-02-00207 | 1400 | 387 | 10 | A |
| TB600-02-00164 | 1500 | 403 | 6 | A / B |
| TB600-02-00202 | 1500 | 405 | 7 | A / B |
| TB600-02-00165 | 1500 | 407 | 8 | A / B |
| TB600-02-00226 | 1600 | 428 | 6 | A / B |
| TB600-02-00220 | 1600 | 433 | 8 | A / B |
| TB600-02-00227 | 1600 | 438 | 10 | A |

Notlar:

•h3 ölçüsü müşteri talebine göre değiştirilebilmektedir.

/ h3 dimension can be changed on customer request.

•t = ham malzeme kalınlığı

/ t = raw material thickness

•Ölçü toleransları için satış bölümümüze danışınız.

/ Please contact our sales team for dimension tolerances.

•Siparişte ürün kodu ve malzeme kalitesi ile birlikte bombe kenar detayını (A / B) mutlaka belirtiniz.

C detayı için satış bölümümüze danışınız.

/ In your inquires, please indicate product code, edge detail (A / B) and material grade. Please contact our sales team for C detail.

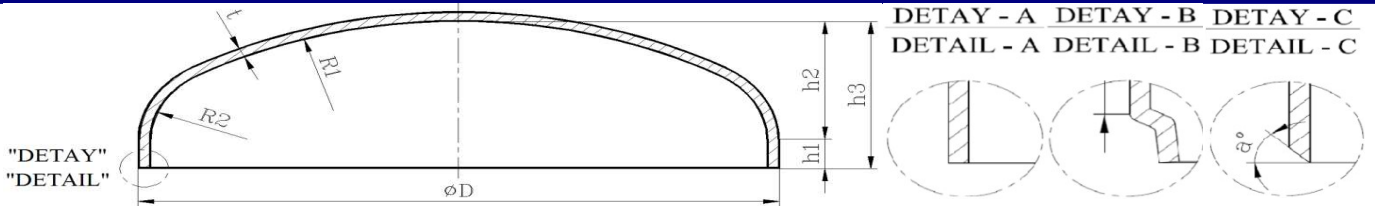

| Ürün Kodu | øD mm | h3 mm | t mm | Detay |
|----------------|----------|----------|---------|-------|
| TB600-01-00001 | 250 | 58 | 2 | A / B |
| TB600-01-00002 | 250 | 62 | 3 | A / B |
| TB600-01-00003 | 250 | 65 | 4 | A / B |
| TB600-01-00004 | 250 | 68 | 5 | A / B |
| TB600-01-00146 | 273 | 63 | 2 | A / B |
| TB600-01-00165 | 273 | 66 | 3 | A / B |
| TB600-01-00182 | 273 | 81 | 8 | A |
| TB600-01-00094 | 273 | 87 | 10 | A |
| TB600-01-00095 | 273 | 93 | 12 | A |
| TB600-01-00096 | 273 | 99 | 14 | A |
| TB600-01-00005 | 300 | 68 | 2 | A / B |
| TB600-01-00006 | 300 | 71 | 3 | A / B |
| TB600-01-00007 | 300 | 74 | 4 | A / B |
| TB600-01-00008 | 300 | 77 | 5 | A / B |
| TB600-01-00166 | 300 | 80 | 6 | A / B |
| TB600-01-00091 | 315 | 71 | 2 | A / B |
| TB600-01-00092 | 315 | 74 | 3 | A / B |
| TB600-01-00093 | 315 | 77 | 4 | A / B |
| TB600-01-00105 | 350 | 78 | 2 | A / B |
| TB600-01-00104 | 350 | 81 | 3 | A / B |
| TB600-01-00106 | 350 | 84 | 4 | A / B |
| TB600-01-00103 | 380 | 87 | 3 | A / B |
| TB600-01-00100 | 380 | 90 | 4 | A / B |
| TB600-01-00101 | 380 | 93 | 5 | A / B |
| TB600-01-00009 | 385 | 85 | 2 | A / B |
| TB600-01-00010 | 385 | 88 | 3 | A / B |
| TB600-01-00011 | 385 | 91 | 4 | A / B |
| TB600-01-00012 | 385 | 94 | 5 | A / B |
| TB600-01-00133 | 385 | 97 | 6 | A / B |
| TB600-01-00013 | 400 | 87 | 2 | A / B |
| TB600-01-00014 | 400 | 91 | 3 | A / B |
| TB600-01-00015 | 400 | 94 | 4 | A / B |
| TB600-01-00016 | 400 | 97 | 5 | A / B |
| TB600-01-00120 | 400 | 118 | 12 | A |
| TB600-01-00122 | 406 | 95 | 4 | A / B |
| TB600-01-00124 | 406 | 98 | 5 | A / B |
| TB600-01-00125 | 406 | 101 | 6 | A / B |
| TB600-01-00017 | 450 | 97 | 2 | A / B |
| TB600-01-00018 | 450 | 100 | 3 | A / B |
| TB600-01-00019 | 450 | 103 | 4 | A / B |
| TB600-01-00020 | 450 | 106 | 5 | A / B |

Notlar:

•h3 ölçüsü müşteri talebine göre değiştirilebilmektedir.

/ h3 dimension can be changed on customer request.

•t = ham malzeme kalınlığı

/ t = raw material thickness

•Ölçü toleransları için satış bölümümüze danışınız.

/ Please contact our sales team for dimension tolerances.

•Siparişte ürün kodu ve malzeme kalitesi ile birlikte bombe kenar detayını (A / B) mutlaka belirtiniz.

C detayı için satış bölümümüze danışınız.

/ In your inquires, please indicate product code, edge detail (A / B) and material grade. Please contact our sales team for C detail.

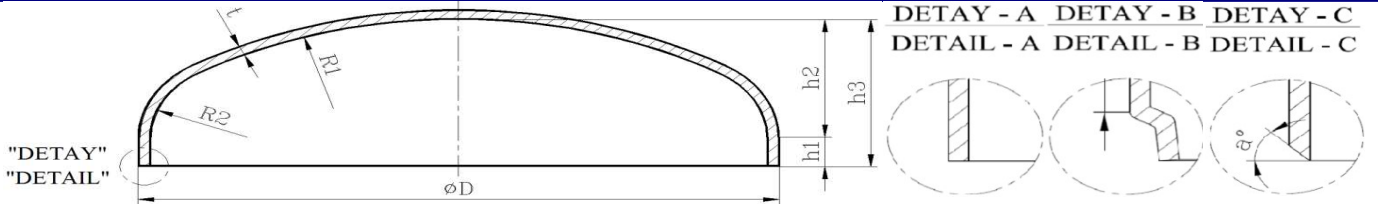

| Ürün Kodu | øD mm | h3 mm | t mm | Detay |
|----------------|----------|----------|---------|-------|
| TB600-01-00075 | 480 | 103 | 2 | A / B |
| TB600-01-00076 | 480 | 106 | 3 | A / B |
| TB600-01-00077 | 480 | 109 | 4 | A / B |
| TB600-01-00078 | 480 | 112 | 5 | A / B |
| TB600-01-00022 | 500 | 110 | 3 | A / B |
| TB600-01-00023 | 500 | 113 | 4 | A / B |
| TB600-01-00024 | 500 | 116 | 5 | A / B |
| TB600-01-00025 | 500 | 119 | 6 | A / B |
| TB600-01-00114 | 500 | 122 | 7 | A |
| TB600-01-00085 | 500 | 125 | 8 | A |
| TB600-01-00167 | 508 | 111 | 3 | A / B |
| TB600-01-00168 | 508 | 114 | 4 | A / B |
| TB600-01-00143 | 508 | 118 | 5 | A / B |
| TB600-01-00183 | 508 | 121 | 6 | A / B |
| TB600-01-00180 | 508 | 127 | 8 | A |
| TB600-01-00184 | 508 | 139 | 12 | A |
| TB600-01-00088 | 545 | 119 | 3 | A / B |
| TB600-01-00089 | 545 | 122 | 4 | A / B |
| TB600-01-00086 | 545 | 125 | 5 | A / B |
| TB600-01-00090 | 545 | 128 | 6 | A / B |
| TB600-01-00176 | 550 | 135 | 8 | A |
| TB600-01-00026 | 587 | 133 | 5 | A / B |
| TB600-01-00128 | 587 | 136 | 6 | A / B |
| TB600-01-00027 | 600 | 126 | 2 | A / B |
| TB600-01-00028 | 600 | 129 | 3 | A / B |
| TB600-01-00029 | 600 | 132 | 4 | A / B |
| TB600-01-00030 | 600 | 135 | 5 | A / B |
| TB600-01-00031 | 600 | 138 | 6 | A / B |
| TB600-01-00154 | 640 | 134 | 2 | A / B |
| TB600-01-00102 | 640 | 137 | 3 | A / B |
| TB600-01-00032 | 640 | 140 | 4 | A / B |
| TB600-01-00033 | 640 | 143 | 5 | A / B |
| TB600-01-00034 | 640 | 146 | 6 | A / B |
| TB600-01-00035 | 640 | 149 | 7 | A |
| TB600-01-00134 | 640 | 152 | 8 | A |
| TB600-01-00135 | 650 | 160 | 10 | A |
| TB600-01-00142 | 650 | 166 | 12 | A |

Notlar:

•h3 ölçüsü müşteri talebine göre değiştirilebilmektedir.

/ h3 dimension can be changed on customer request.

•t = ham malzeme kalınlığı

/ t = raw material thickness

•Ölçü toleransları için satış bölümümüze danışınız.

/ Please contact our sales team for dimension tolerances.

•Siparişte ürün kodu ve malzeme kalitesi ile birlikte bombe kenar detayını (A / B) mutlaka belirtiniz.

C detayı için satış bölümümüze danışınız.

/ In your inquires, please indicate product code, edge detail (A / B) and material grade. Please contact our sales team for C detail.

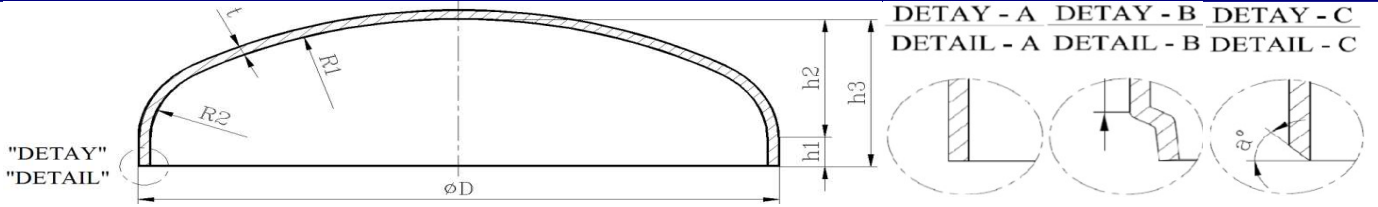

| Ürün Kodu | ØD mm | h3 mm | t mm | Detay |
|----------------|----------|----------|---------|-------|
| TB600-01-00037 | 700 | 149 | 3 | A / B |
| TB600-01-00038 | 700 | 152 | 4 | A / B |
| TB600-01-00039 | 700 | 155 | 5 | A / B |
| TB600-01-00040 | 700 | 158 | 6 | A / B |
| TB600-01-00115 | 750 | 161 | 4 | A / B |
| TB600-01-00116 | 750 | 164 | 5 | A / B |
| TB600-01-00117 | 750 | 167 | 6 | A / B |
| TB600-01-00108 | 750 | 170 | 7 | A |
| TB600-01-00118 | 750 | 173 | 8 | A |
| TB600-01-00119 | 750 | 180 | 10 | A |
| TB600-01-00153 | 790 | 166 | 3 | A / B |
| TB600-01-00154 | 790 | 169 | 4 | A / B |
| TB600-01-00155 | 790 | 172 | 5 | A / B |
| TB600-01-00185 | 790 | 175 | 6 | A / B |
| TB600-01-00041 | 804 | 166 | 2 | A / B |
| TB600-01-00042 | 804 | 169 | 3 | A / B |
| TB600-01-00043 | 804 | 172 | 4 | A / B |
| TB600-01-00044 | 804 | 175 | 5 | A / B |
| TB600-01-00045 | 804 | 178 | 6 | A / B |
| TB600-01-00129 | 804 | 181 | 7 | A |
| TB600-01-00109 | 804 | 184 | 8 | A |
| TB600-01-00169 | 850 | 181 | 4 | A / B |
| TB600-01-00046 | 850 | 184 | 5 | A / B |
| TB600-01-00047 | 850 | 187 | 6 | A / B |
| TB600-01-00048 | 850 | 190 | 7 | A / B |
| TB600-01-00049 | 850 | 193 | 8 | A / B |
| TB600-01-00139 | 850 | 199 | 10 | A |
| TB600-01-00140 | 850 | 205 | 12 | A |
| TB600-01-00141 | 850 | 211 | 14 | A |
| TB600-01-00162 | 900 | 187 | 3 | A / B |
| TB600-01-00160 | 900 | 190 | 4 | A / B |
| TB600-01-00163 | 900 | 193 | 5 | A / B |
| TB600-01-00164 | 900 | 196 | 6 | A / B |
| TB600-01-00171 | 950 | 194 | 2 | A / B |
| TB600-01-00172 | 950 | 195 | 2,5 | A / B |
| TB600-01-00051 | 958 | 199 | 3 | A / B |
| TB600-01-00052 | 958 | 202 | 4 | A / B |
| TB600-01-00053 | 958 | 205 | 5 | A / B |
| TB600-01-00054 | 958 | 208 | 6 | A / B |

Notlar:

•h3 ölçüsü müşteri talebine göre değiştirilebilmektedir.

/ h3 dimension can be changed on customer request.

•t = ham malzeme kalınlığı

/ t = raw material thickness

•Ölçü toleransları için satış bölümümüze danışınız.

/ Please contact our sales team for dimension tolerances.

•Siparişte ürün kodu ve malzeme kalitesi ile birlikte bombe kenar detayını (A / B) mutlaka belirtiniz.

C detayı için satış bölümümüze danışınız.

/ In your inquires, please indicate product code, edge detail (A / B) and material grade. Please contact our sales team

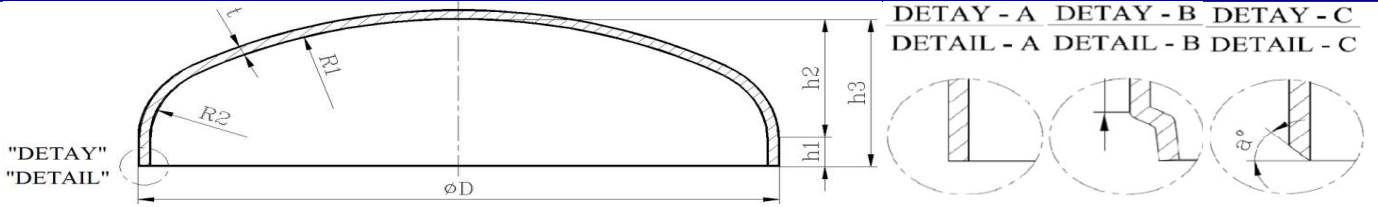

| Ürün Kodu | øD mm | h3 mm | t mm | Detay |
|----------------|----------|----------|---------|-------|
| TB600-01-00055 | 1000 | 209 | 3 | A / B |
| TB600-01-00056 | 1000 | 212 | 4 | A / B |
| TB600-01-00057 | 1000 | 215 | 5 | A / B |
| TB600-01-00058 | 1000 | 218 | 6 | A / B |
| TB600-01-00059 | 1000 | 221 | 7 | A / B |
| TB600-01-00060 | 1000 | 224 | 8 | A / B |
| TB600-01-00170 | 1100 | 225 | 2 | A / B |
| TB600-01-00130 | 1100 | 228 | 3 | A / B |
| TB600-01-00061 | 1100 | 231 | 4 | A / B |
| TB600-01-00062 | 1100 | 234 | 5 | A / B |
| TB600-01-00063 | 1100 | 237 | 6 | A / B |
| TB600-01-00064 | 1100 | 240 | 7 | A / B |
| TB600-01-00065 | 1100 | 243 | 8 | A / B |
| TB600-01-00147 | 1150 | 238 | 3 | A / B |
| TB600-01-00143 | 1150 | 241 | 4 | A / B |
| TB600-01-00148 | 1150 | 244 | 5 | A / B |
| TB600-01-00149 | 1150 | 247 | 6 | A / B |
| TB600-01-00159 | 1150 | 253 | 8 | A / B |
| TB600-01-00066 | 1200 | 247 | 3 | A / B |
| TB600-01-00067 | 1200 | 250 | 4 | A / B |
| TB600-01-00068 | 1200 | 253 | 5 | A / B |
| TB600-01-00069 | 1200 | 256 | 6 | A / B |
| TB600-01-00111 | 1200 | 260 | 7 | A / B |
| TB600-01-00070 | 1200 | 263 | 8 | A / B |
| TB600-01-00150 | 1300 | 276 | 6 | A / B |
| TB600-01-00151 | 1300 | 279 | 7 | A / B |
| TB600-01-00152 | 1300 | 282 | 8 | A / B |
| TB600-01-00071 | 1500 | 311 | 5 | A / B |
| TB600-01-00072 | 1500 | 315 | 6 | A / B |
| TB600-01-00073 | 1500 | 318 | 7 | A / B |
| TB600-01-00074 | 1500 | 321 | 8 | A / B |
| TB600-01-00156 | 1600 | 334 | 6 | A / B |
| TB600-01-00157 | 1600 | 337 | 7 | A / B |
| TB600-01-00158 | 1600 | 340 | 8 | A / B |

Notlar:

•h3 ölçüsü müşteri talebine göre değiştirilebilmektedir.

/ h3 dimension can be changed on customer request.

•t = ham malzeme kalınlığı

/ t = raw material thickness

•Ölçü toleransları için satış bölümümüze danışınız.

/ Please contact our sales team for dimension tolerances.

•Siparişte ürün kodu ve malzeme kalitesi ile birlikte bombe kenar detayını (A / B) mutlaka belirtiniz.

C detayı için satış bölümümüze danışınız.

/ In your inquiries, please indicate product code, edge detail (A / B) and material grade. Please contact our sales team for C detail.

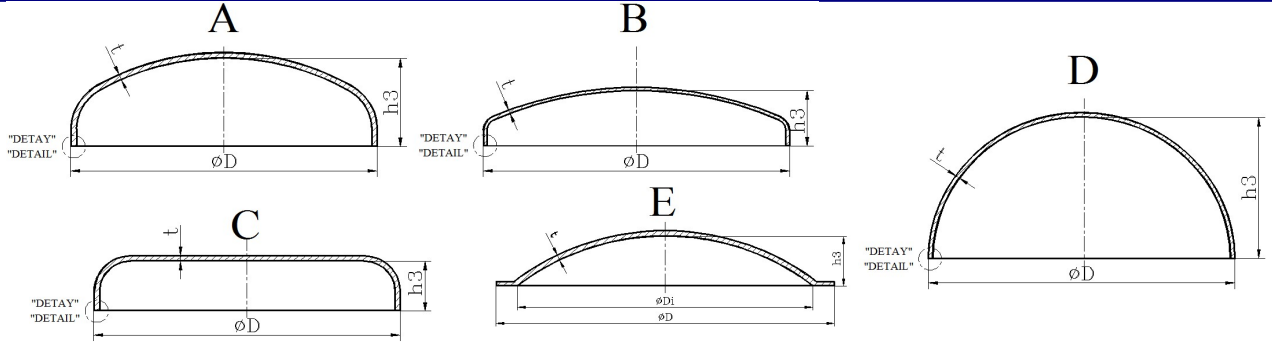

| Ürün Kodu Product Code | øD mm | h3 mm | t mm | Şekil Shape |
|---------------------------|----------|----------|---------|----------------|
| TB600-00-00091 | 89 | 45 | 2 | D |
| TB600-00-00078 | 160 | 55 | 1,5 | A |
| TB600-00-00010 | 160 | 65 | 2 | A |
| TB600-00-00012 | 165 | 65 | 10 | A |
| TB600-00-00093 | 205 | 65 | 5 | C |
| TB600-09-00116 | 250 | 25 | 2 | C |
| TB600-53-00003 | 250 | 125 | 2 | D |
| TB600-53-00005 | 250 | 125 | 3 | D |
| TB600-00-00015 | 273 | 80 | 3 | C |
| TB600-09-00117 | 300 | 25 | 2 | C |
| TB600-09-00107 | 300 | 35 | 8 | C |
| TB600-09-00101 | 300 | 50 | 4 | C |
| TB600-00-00094 | 300 | 94 | 6 | C |
| TB600-53-60003 | 300 | 146 | 4 | D |
| TB600-00-00016 | 315 | 120 | 3 | A |
| TB600-00-00249 | 323 | 61 | 5 | B |
| TB600-00-00017 | 323 | 100 | 4 | C |
| TB600-09-00118 | 350 | 20 | 2 | C |
| TB600-53-00006 | 350 | 175 | 3,5 | D |
| TB600-00-70012 | 360 | 121 | 2,5 | A |
| TB600-09-00108 | 360 | 150 | 2,5 | C |
| TB600-00-00250 | 360 | 170 | 2 | A |
| TB600-00-00226 | 360 | 170 | 3 | A |
| TB600-00-10123 | 380 | 110 | 4 | A |
| TB600-00-70013 | 390 | 111 | 2,5 | A |
| TB600-09-00115 | 400 | 25 | 2 | C |
| TB600-00-10112K | 400 | 125 | 5 | A |
| TB600-00-20163K | 400 | 125 | 6 | A |
| TB600-09-00109 | 406 | 86 | 4 | C |
| TB600-09-00110 | 445 | 60 | 2 | C |
| TB600-00-00098 | 480 | 109 | 3 | B |
| TB600-00-20132K | 480 | 153 | 6 | A |
| TB600-09-00102 | 500 | 26 | 4 | C |
| TB600-09-00111 | 500 | 35 | 3 | C |
| TB600-09-00112 | 500 | 68 | 2 | C |
| TB600-00-00079 | 500 | 250 | 2 | D |
| TB600-53-00007 | 500 | 250 | 2,5 | D |
| TB600-00-00080 | 500 | 250 | 3 | D |

Notlar:

•h3 ölçüsü müşteri talebine göre değiştirilebilmektedir.

/ h3 dimension can be changed on customer request.

•t = ham malzeme kalınlığı

/ t = raw material thickness

•Ölçü toleransları için satış bölümümüze danışınız.

/ Please contact our sales team for dimension tolerances.

•Siparişte ürün kodunu mutlaka belirtiniz.

/ In your inquires, please indicate product code

İnönü Mah. Gebze Plastikçiler Organize Sanayi Bölgesi (GEPOSB) 91. Sokak, No: 5/1 41400 Gebze-Kocaeli / TR

T: +90 262 751 31 31 (pbx) F: +90 262 751 31 39

www.teknikbombe.com info@teknikbombe.com

Sayfa_1-2

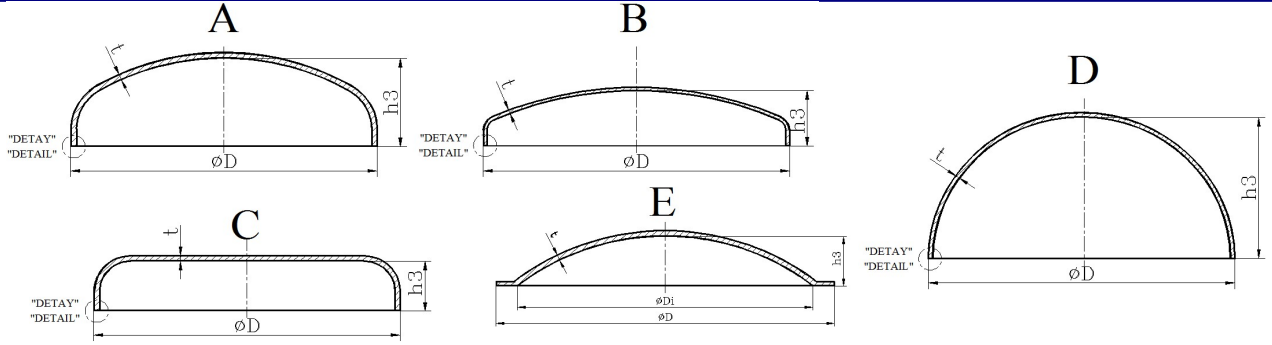

| Ürün Kodu Product Code | øD mm | h3 mm | t mm | Şekil Shape |
|---------------------------|----------|----------|---------|----------------|
| TB600-09-00113 | 508 | 35 | 10 | C |
| TB600-00-70003 | 520 | 120 | 2,5 | A |
| TB600-09-50078 | 545 | 70 | 2 | C |
| TB600-09-00114 | 600 | 50 | 2 | C |
| TB600-00-50227 | 600 | 75 | 2,5 | C |
| TB600-00-10066 | 600 | 129 | 6 | A |
| TB600-53-50008 | 600 | 300 | 12 | D |
| TB600-00-70004 | 640 | 170 | 2,5 | A |
| TB600-09-50093 | 640 | 130 | 3 | C |
| TB600-00-00038 | 640 | 139 | 3 | A |
| TB600-00-00081 | 640 | 139 | 4 | A |
| TB600-00-00082 | 640 | 139 | 5 | A |
| TB600-00-00073 | 640 | 139 | 6 | A |
| TB600-00-00083 | 640 | 139 | 7 | A |
| TB600-00-00039 | 640 | 191 | 8 | A |
| TB600-43-50004 | 750 | 375 | 2 | D |
| TB600-00-00040 | 804 | 340 | 2 | A |
| TB600-00-00041 | 804 | 340 | 3 | A |
| TB600-00-00042 | 804 | 340 | 4 | A |
| TB600-00-00084 | 804 | 340 | 5 | A |
| TB600-00-00043 | 804 | 340 | 6 | A |
| TB600-00-00175 | 850 | 305 | 3 | A |
| TB600-53-80001 | 1000 | 500 | 3 | D |
| TB600-00-00209 | 1300 | 245 | 6 | A |
| TB600-00-00210 | 1300 | 245 | 7 | A |
| TB600-00-00211 | 1300 | 245 | 8 | A |
| TB600-52-B2002 | 1349 | 100 | 8 | E |

Notlar:

•h3 ölçüsü müşteri talebine göre değiştirilebilmektedir.

/ h3 dimension can be changed on customer request.

•t = ham malzeme kalınlığı

/ t = raw material thickness

•Ölçü toleransları için satış bölümümüze danışınız.

/ Please contact our sales team for dimension tolerances.

•Siparişte ürün kodunu mutlaka belirtiniz.

/ In your inquires, please indicate product code.